

Semiconductor Flow Equipment

Ultra High Purity Tubes & Fittings



Semiconductor



Bio-Pharm



Hygienic



NEUMO



H.P.T.



EGMO

NEUMO Ehrenberg Group

SciMax® - Ultra Purity With Guaranteed Ra

SciMax Semiconductor Flow Equipment is specially designed to meet the stringent standards of the semiconductor industry, delivering maximum results.

Maximum Guaranteed Ra

Using unique polishing technology, EGMO guarantees the RA in all internal surfaces, including bent areas where it is difficult to polish and difficult to measure.

Maximum Cleanability

The multi-step cleaning cycle (degreasing, pickling, and electro-polishing) is conducted to ensure that products are cleaned with a perfect passivation layer. Final cleaning with ultra pure water is undertaken in a clean room.

Maximum Availability

State-of-the-art manufacturing facilities and full marketing, distribution, and support in Europe, the USA, and Asia enables EGMO to supply semiconductor flow equipment of the highest quality standards to meet the customer's demands.

Full Traceability

Each step of our production process is documented and recorded starting from raw materials through finished goods.



About EGMO

EGMO, a member of NEUMO Ehrenberg Group, is a worldwide leader in the manufacturing of high purity, stainless steel products for the Semiconductor, Biopharmaceutical and Food industries. Founded in 1965, EGMO offers its customers decades of experience in innovative development and production of an extensive range of tubes, fittings, valves, vessels and other special components. EGMO is ISO 9001:2008, CE, ASME & CRN certified and its products also meet the following standards: TUV, 3A, DIN, ISO, CE, SMS, BS (RJT).

NEUMO Ehrenberg Group

The NEUMO Ehrenberg Group, a diversified multinational organization headquartered in Germany, was founded by Senator Henry Ehrenberg in 1947. The know-how, experience, and impressive track record of its companies, NEUMO, VNE and EGMO, have been earned over four decades. Today, the group is a leading manufacturer of worldwide stainless-steel process fittings and components. The Group's worldwide distribution network supports major multinational accounts.



| www.egmo.co.il |

Index

Fittings Specifications Page 4

Inspection Test and Documentation Page 5

How to Order Page 6

Tubes Page 9

Fitting Types Page 10



Elbows | Page 10 |



Tees | Page 11-12 |



Reducers | Page 13 |



End Caps | Page 14 |



COAX | Page 15-17 |

Laterals and Manifolds Page 18

Technical Information Page 20

MTR - Material Test Report Page 22

Product Specification

	SCiMax30	SCiMax20	SCiMax10	SCiMax5
Application	CFOS	CFOS	Ultra High Purity	Ultra High Purity
Material	304L	316L	316L	316L
ID Ra (Inch/meter)	30/.75	20 /0.5	10 /0.25	5 /0.125
Surface Treatment	MP*	MP*/EP	EP	EP
Final Cleaning	DI-WATER	DI-WATER	UPW 18MΩ	UPW 18MΩ
Packing Environment Area	Class 100,000	Class 1,000	Class 10	Class 10
Packing & Capping	N2 purge + PE cap + PE bag	N2 purge +PE cap + PE bag	UHP N2 purge + PE cap + Double PE bag	UHP N2 purge + PE cap + Double PE bag
Marking	All SCiMax products are marked as follows: • Brand name • Job number • Material grade • Dimensions • Heat number			

Inspection Tests and Documentation

Summary table of testing, inspection and certification that can be given per our process.

Description	Standard / Value	SciMax30	SciMax20	SciMax10	SciMax5
Material Composition	ASTM A269/A270, A632	✓	✓	✓	✓
Mechanical Tests	ASTM A269, A632	✓	✓	✓	✓
Visual Inspection 100%	Internal procedure	✓	✓	✓	✓
Dimensional Measurements	ANSI B31.3	✓	✓	✓	✓
Hydrocarbon Cleaning Inspection	CGA G-4.1	✓	✓	✓	✓
Helium Leak Test for Welded Fittings	1*10 ⁻⁹ scc/sec	✓	✓	✓	✓
Inspection Certification	EN 10204 3.1	✓	✓	✓	✓
Ra Measurements	ASME B46.1	✓	✓	✓	✓
Particles Test	<10 particles (greater than 0.1μ ft ³)			✓	✓
Moisture Test for Tube: Additional Moisture on UHP N2 Purged Gas	Δ0.5 ppm			✓	✓
Ultra Pure Water Resistivity	18 MΩ			✓	✓
SEM TEST - Scanning Electron Microscopy for Defects	SEMATECH 90120401B 40 defects (magnification*3500)			✓	✓
XPS TEST - X Ray Photoelectron Spectroscopy for Analysis of Cr/Fe	SEMATECH 90120403B 1.5/1<			✓	✓
XPS TEST - X Ray Photoelectron Spectroscopy for Analysis of CrO/FeO	SEMATECH 90120403B 3/1 <			✓	✓
AES TEST - Auger Electron Spectroscopy for Measuring of Oxide Thickness	SEMATECH 91060573B / 20 A<			✓	✓

How to order

To specify the part, choose a product line, type of material and then select the code number describing the requested part as shown below:

Tubing:

S M 2 0 3 1 6 L E P W E - . 2 5 X . 0 3 5 S M T 1
 Product Line Material Surface Treatment Type O.D. Size Wall Thickness Inch

Product Line	Material	Surface Treatment	Type	O.D. Size	Wall Thickness Inch
SM30 - SCiMax 30	316L	EP - Electro Polish	WE - Welded	¼" - .25	.035
SM20 - SCiMax 20	304L	BA - Bright Annealed	SL - Seamless	⅜" - .375	.035
SM10 - SCiMax 10				½" - .5	.049
SM5 - SCiMax 5				½" - .5	.065
				¾" - .75	.065
				1" - 1.0	.065
				1½" - 1.5	.065
				2" - 2.0	.065
				2½" - 2.5	.065
				3" - 3.0	.065
				4" - 4.0	.083
				6" - 6.0	.109

For Example: SM10316LEPSL-.25x.035SMT1

Fitting:

S M 2 0 3 1 6 L E P E L 9 0 - . 2 5
 Product Line Material Surface Treatment Shape O.D. Size

Product Line	Material	Surface Treatment	Shape	O.D. Size
SM30 - SCiMax 30	316L	EP - Electro Polish	EL90 - Elbow 90	¼" - .25
SM20 - SCiMax 20	304L	BA - Bright Annealed	EL45 - Elbow 45	⅜" - .375
SM10 - SCiMax 10			ETEE - Equal Tee	½" - .5
SM5 - SCiMax 5			ECAP - End Cap	¾" - .75
				1" - 1.0
				1½" - 1.5
				2" - 2.0
				2½" - 2.5
				3" - 3.0
				4" - 4.0
				6" - 6.0

For Example: SM30316LEPEL45-.5

Reducing Components:

S M 2 0 3 1 6 L E P R T E E - . 3 7 5 X . 2 5
 Product Line Material Surface Treatment Shape O.D. Size Large O.D. Size Small

Product Line	Material	Surface Treatment	Shape	Size Large	Size Small
SM30 - SCiMax 30	316L	EP - Electro Polish	RTEE - Reducing Tee	3/8" - .375	1/4" - .25
SM20 - SCiMax 20	304L	BA - Bright Annealed	CORD - Concentric Reducer	1/2" - .5	3/8" - .375
SM10 - SCiMax 10				3/4" - .75	1/2" - .5
SM5 - SCiMax 5				1" - 1.0	3/4" - .75
				1 1/2" - 1.5	1" - 1.0
				2" - 2.0	1 1/2" - 1.5
				2 1/2" - 2.5	2" - 2.0
				3" - 3.0	2 1/2" - 2.5
				4" - 4.0	3" - 3.0
				6" - 6.0	4" - 4.0

For Example: SM20316LBARTEE-2.0x.375

Coax Tubing:

S M 2 0 C O A X 3 1 6 L E P W E - . 2 5 X . 0 3 5
 Product Line Material Surface Treatment Type O.D. Size Wall Thickness Inch

Product Line	Material	Surface Treatment	Type	Inner Tube Parameters	
				O.D. Size	Wall Thickness Inch
SM30COAX - SCiMax 30 COAX	316L	EP - Electro Polish	WE - Welded	1/4" - .25	.035
SM20COAX - SCiMax 20 COAX	304L	BA - Bright Annealed	SL - Seamless	3/8" - .375	.035
SM10COAX - SCiMax 10 COAX				1/2" - .5	.049
SM5COAX - SCiMax 5 COAX				1/2" - .5	.065
				3/4" - .75	.065
				1" - 1.0	.065

For Example: SM10COAX316LEPSL-.25x.035

How to order

Coax Fitting:

S M 1 0 C O A X 3 1 6 L E P E L 9 0 - . 2 5
 Product Line Material Surface Treatment Shape O.D. Size

Product Line	Inner Tube Parameters			
	Material	Surface Treatment	Shape	O.D. Size
SM30COAX - SCiMax 30 COAX	316L	EP - Electro Polish	EL90 - Elbow 90	¼" - .25
SM20COAX - SCiMax 20 COAX	304L	BA - Bright Annealed	EL45 - 45	⅜" - .375
SM10COAX - SCiMax 10 COAX			ETEE - Equal Tee	½" - .5
SM5COAX - SCiMax 5 COAX			* PTEE - Purge Tee	¾" - .75
			* SLVE - Sleeve	1" - 1.0
			* TERM - Terminator	

For Example: SM10COAX316LEPEL45-.5

* Size refers to outer tube

Coax Reducing Components:

S M 2 0 C O A X 3 1 6 L E P R T E E - . 3 7 5 X . 2 5
 Product Line Material Surface Treatment Shape O.D. Size Large O.D. Size Small

Product Line	Inner Tube Parameters				
	Material	Surface Treatment	Shape	Size Large	Size Small
SM30COAX - SCiMax 30 COAX	316L	EP - Electro Polish	RTEE - Reducing Tee	⅜" - .375	¼" - .25
SM20COAX - SCiMax 20 COAX	304L	BA - Bright Annealed		½" - .5	⅜" - .375
SM10COAX - SCiMax 10 COAX				¾" - .75	½" - .5
SM5COAX - SCiMax 5 COAX				1" - 1.0	¾" - .75

For Example: SM10COAX316LEPRTEE-.5x.25

Tubes

Tube Dimensions

O.D. Size Inch	Surface Finish	Wall Thickness		Catalog# EP	Catalog# BA
		t inch	t mm		
1/4"	Seamless	0.035	0.89	581-00236	581-00241
3/8"	Seamless	0.035	0.89	581-00237	581-00242
1/2"	Seamless	0.049	1.24	581-00238	581-00243
3/4"	Seamless	0.065	1.65	581-00239	581-00244
1"	Seamless	0.065	1.65	581-00240	581-00245
1"	Welded	0.065	1.65	581-00019	581-00005
1 1/2"	Welded	0.065	1.65	581-00026	581-00006
2"	Welded	0.065	1.65	581-00028	581-00027
2 1/2"	Welded	0.065	1.65	581-00029	581-00008
3"	Welded	0.065	1.65	581-00030	581-00009
4"	Welded	0.083	2.11	581-00031	581-00010
6"	Welded	0.109	2.77	581-00032	581-00011

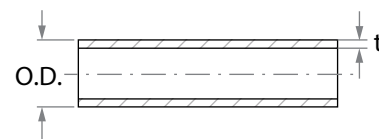

* How to order - see page 6

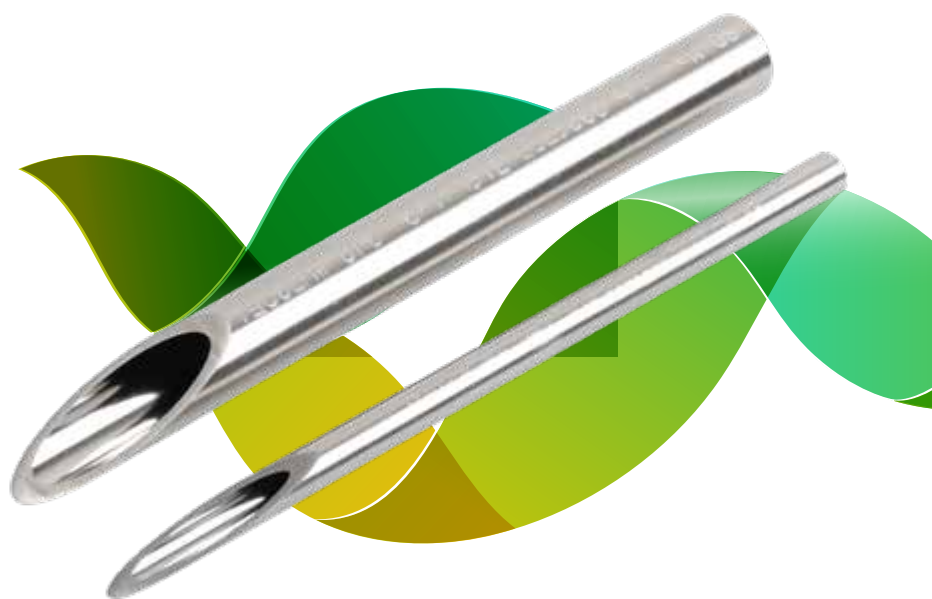

Elbows

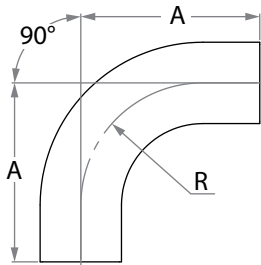

EL90 - Elbow 90°

O.D. Size Inch	Dimensions				Catalog# EP		Catalog# BA	
	A inch	A mm	R inch	R mm	SCiMax 10	SCiMax 20	SCiMax 10	SCiMax 20
¼"	2.625	66.7	0.62	15.90	580-00027	580-00049		
⅜"	2.625	66.7	1.00	25.40	580-00028	580-00050		
½"	3.00	76.2	1.13	28.60	580-00029	580-00006		
¾"	3.00	76.2	1.13	28.60	580-00030	580-00014		
1"	3.00	76.2	1.50	38.10	580-00031	580-00002		
1½"	3.75	95.3	2.25	57.20	580-00032	580-00004		
2"	4.75	120.7	3.00	76.20	580-00033	580-00008		
2½"	5.50	139.7	3.75	95.25	580-00034	580-00010		
3"	6.25	158.8	4.50	114.30	580-00035	580-00012		
4"	8.00	203.2	6.00	152.40	580-00036	580-00016		
6"	11.50	292.1	9.00	228.60	580-00037	580-00109		

* **How to order** - see page 6

** *For wall thickness please refer to page 9*

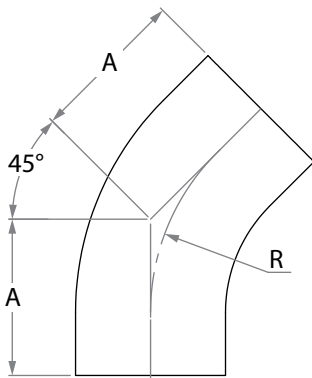

EL45 - Elbow 45°

O.D. Size Inch	Dimensions				Catalog# EP		Catalog# BA	
	A inch	A mm	R inch	R mm	SCiMax 10	SCiMax 20	SCiMax 10	SCiMax 20
¼"	2.000	50.8	0.62	15.75	580-00038	580-00152		
⅜"	2.000	50.8	1.00	25.40	580-00039	580-00153		
½"	2.250	57.2	1.13	28.60	580-00040	580-00005		
¾"	2.250	57.2	1.13	28.60	580-00041	580-00013		
1"	2.250	57.2	1.50	38.10	580-00026	580-00001		
1½"	2.500	63.5	2.25	57.20	580-00043	580-00003		
2"	3.000	76.2	3.00	76.20	580-00044	580-00007		
2½"	3.375	85.7	3.75	95.25	580-00045	580-00009		
3"	3.625	92.1	4.50	114.30	580-00046	580-00011		
4"	4.500	114.3	6.00	152.40	580-00048	580-00015		
6"	6.250	158.8	9.00	228.60	580-00047	580-00154		

* **How to order** - see page 6

** *For wall thickness please refer to page 9*

Tees

ETEE - Equal Tee

O.D. Size Inch	Dimensions				Catalog# EP	Catalog# BA
	A inch	A mm	B inch	B mm	SciMax 10	SciMax 20
¼"	3.500	88.90	1.750	44.50	579-00059	579-00049
⅜"	3.500	88.90	1.750	44.50	579-00060	579-00179
½"	3.750	95.25	1.875	47.60	579-00062	579-00038
¾"	4.000	101.60	2.000	50.80	579-00065	579-00041
1"	4.250	108.00	2.125	54.00	579-00069	579-00035
1½"	4.750	120.60	2.375	60.30	579-00074	579-00036
2"	5.750	146.00	2.875	73.00	579-00080	579-00039
2½"	6.250	158.75	3.125	79.40	579-00087	579-00449
3"	6.750	171.40	3.375	85.70	579-00095	579-00040
4"	8.250	209.60	4.125	104.80	579-00102	579-00042
6"	11.25	285.80	5.625	142.90	579-00110	579-00450

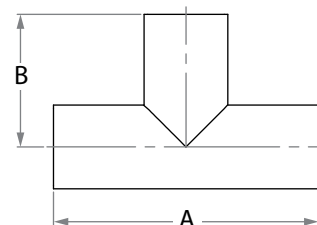

* How to order - see page 6

** For wall thickness please refer to page 9

RTEE - Reducing Tee

O.D. Size Inch	Dimensions				Catalog# EP	Catalog# BA
	A inch	A mm	B inch	B mm	SciMax 10	SciMax 20
⅜" x ¼"	3.50	88.90	1.750	44.45	579-00061	579-00451
½" x ¼"	3.75	95.30	1.875	47.65	579-00063	579-00044
½" x ⅜"	3.75	95.30	1.875	47.65	579-00064	579-00183
¾" x ¼"	4.00	101.60	2.000	50.80	579-00066	579-00453
¾" x ⅜"	4.00	101.60	2.000	50.80	579-00067	579-00454
¾" x ½"	4.00	101.60	2.000	50.80	579-00068	579-00023
1" x ¼"	4.25	108.00	2.125	54.00	579-00070	579-00455
1" x ⅜"	4.25	108.00	2.125	54.00	579-00071	579-00456
1" x ½"	4.25	108.00	2.125	54.00	579-00072	579-00002
1" x ¾"	4.25	108.00	2.125	54.00	579-00073	579-00003
1½" x ¼"	4.75	120.70	2.375	60.30	579-00075	579-00425
1½" x ⅜"	4.75	120.70	2.375	60.30	579-00076	579-00457
1½" x ½"	4.75	120.70	2.375	60.30	579-00077	579-00006
1½" x ¾"	4.75	120.70	2.375	60.30	579-00078	579-00007
1½" x 1"	4.75	120.70	2.375	60.30	579-00079	579-00004

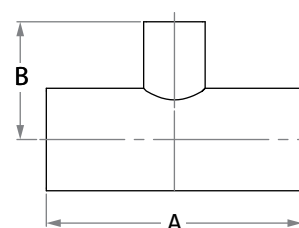

* How to order - see page 7

** For wall thickness please refer to page 9

Tees

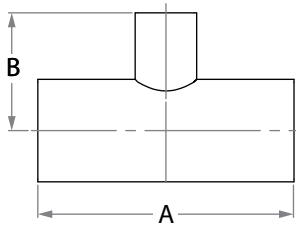

RTEE - Reducing Tee

O.D. Size Inch	Dimensions				Catalog# EP		Catalog# BA	
	A inch	A mm	B inch	B mm	SCiMax 10	SCiMax 20		
2" x 1/4"	5.75	146.00	2.625	66.70	579-00081	579-00458		
2" x 3/8"	5.75	146.00	2.625	66.70	579-00082	579-00459		
2" x 1/2"	5.75	146.00	2.625	66.70	579-00083	579-00010		
2" x 3/4"	5.75	146.00	2.625	66.70	579-00084	579-00011		
2" x 1"	5.75	146.00	2.625	66.70	579-00085	579-00008		
2" x 1 1/2"	5.75	146.00	2.625	66.70	579-00086	579-00009		
2 1/2" x 1/4"	6.25	158.80	2.875	73.00	579-00088	579-00460		
2 1/2" x 3/8"	6.25	158.80	2.875	73.00	579-00089	579-00461		
2 1/2" x 1/2"	6.25	158.80	2.875	73.00	579-00090	579-00014		
2 1/2" x 3/4"	6.25	158.80	2.875	73.00	579-00091	579-00016		
2 1/2" x 1"	6.25	158.80	2.875	73.00	579-00092	579-00012		
2 1/2" x 1 1/2"	6.25	158.80	2.875	73.00	579-00093	579-00013		
2 1/2" x 2"	6.25	158.80	2.875	73.00	579-00094	579-00015		
3" x 1/4"	6.75	171.50	3.125	79.40	579-00437	579-00462		
3" x 3/8"	6.75	171.50	3.125	79.40	579-00438	579-00548		
3" x 1/2"	6.75	171.50	3.125	79.40	579-00096	579-00019		
3" x 3/4"	6.75	171.50	3.125	79.40	579-00097	579-00022		
3" x 1"	6.75	171.50	3.125	79.40	579-00098	579-00017		
3" x 1 1/2"	6.75	171.50	3.125	79.40	579-00099	579-00018		
3" x 2"	6.75	171.50	3.125	79.40	579-00100	579-00020		
3" x 2 1/2"	6.75	171.50	3.125	79.40	579-00101	579-00021		
4" x 1/4"	8.25	209.60	3.625	92.10	579-00439	579-00549		
4" x 3/8"	8.25	209.60	3.625	92.10	579-00440	579-00550		
4" x 1/2"	8.25	209.60	3.625	92.10	579-00103	579-00027		
4" x 3/4"	8.25	209.60	3.625	92.10	579-00104	579-00024		
4" x 1"	8.25	209.60	3.625	92.10	579-00105	579-00025		
4" x 1 1/2"	8.25	209.60	3.625	92.10	579-00106	579-00026		
4" x 2"	8.25	209.60	3.875	98.40	579-00107	579-00028		
4" x 2 1/2"	8.25	209.60	3.875	98.40	579-00108	579-00029		
4" x 3"	8.25	209.60	3.875	98.40	579-00109	579-00030		
6" x 1/4"	11.25	285.80	4.875	123.80	579-00441	579-00551		
6" x 1/2"	11.25	285.80	4.875	123.80	579-00111	579-00463		
6" x 3/4"	11.25	285.80	4.875	123.80	579-00112	579-00464		
6" x 1"	11.25	285.80	4.875	123.80	579-00113	579-00465		
6" x 1 1/2"	11.25	285.80	4.875	123.80	579-00114	579-00466		
6" x 2"	11.25	285.80	4.875	123.80	579-00115	579-00467		
6" x 3"	11.25	285.80	4.875	123.80	579-00117	579-00468		
6" x 4"	11.25	285.80	5.625	142.90	579-00118	579-00469		

* How to order - see page 7

** For wall thickness please refer to page 9

Reducers

CORD - Concentric Reducer

O.D. Size Inch	Dimensions		Catalog# EP	Catalog# BA
	A inch	A mm	SciMax 10	SciMax 20
3/8" x 1/4"	1.625	41.28	578-00032	578-00269
1/2" x 1/4"	1.875	47.63	578-00033	578-00025
1/2" x 3/8"	1.875	47.63	578-00034	578-00270
3/4" x 1/4"	1.875	47.63	578-00035	578-00271
3/4" x 3/8"	1.875	47.63	578-00036	578-00272
3/4" x 1/2"	1.875	47.63	578-00037	578-00024
1" x 1/4"	2.125	53.97	578-00038	578-00084
1" x 3/8"	2.125	53.97	578-00039	578-00085
1" x 1/2"	2.125	53.97	578-00040	578-00009
1" x 3/4"	2.125	53.97	578-00041	578-00019
1 1/2" x 1/4"	2.250	57.15	578-00042	578-00339
1 1/2" x 3/8"	2.250	57.15	578-00043	578-00087
1 1/2" x 1/2"	2.250	57.15	578-00044	578-00023
1 1/2" x 3/4"	2.250	57.15	578-00045	578-00026
1 1/2" x 1"	2.250	57.15	578-00046	578-00022
2" x 1/4"	2.750	69.85	578-00047	578-00340
2" x 3/8"	2.750	69.85	578-00048	578-00273
2" x 1/2"	2.750	69.85	578-00049	578-00010
2" x 3/4"	2.750	69.85	578-00050	578-00020
2" x 1"	2.750	69.85	578-00051	578-00076
2" x 1 1/2"	2.750	69.85	578-00052	578-00005
2 1/2" x 1/2"	3.500	88.90	578-00053	578-00011
2 1/2" x 3/4"	3.500	88.90	578-00054	578-00027
2 1/2" x 1"	3.500	88.90	578-00055	578-00002
2 1/2" x 1 1/2"	3.500	88.90	578-00056	578-00006
2 1/2" x 2"	3.500	88.90	578-00057	578-00013
3" x 1/2"	4.250	108.00	578-00058	578-00012
3" x 3/4"	4.250	108.00	578-00059	578-00021
3" x 1"	4.250	108.00	578-00060	578-00003
3" x 1 1/2"	4.250	108.00	578-00061	578-00007
3" x 2"	4.250	108.00	578-00062	578-00014
3" x 2 1/2"	4.250	108.00	578-00063	578-00016
4" x 3/4"	5.000	127.00	578-00064	578-00274
4" x 1"	5.000	127.00	578-00065	578-00004
4" x 1 1/2"	5.000	127.00	578-00066	578-00008
4" x 2"	5.000	127.00	578-00067	578-00089
4" x 2 1/2"	5.000	127.00	578-00068	578-00017
4" x 3"	5.000	127.00	578-00069	578-00018
6" x 1"	6.000	152.40	578-00070	578-00275
6" x 1 1/2"	6.000	152.40	578-00071	578-00276
6" x 2"	6.000	152.40	578-00072	578-00277
6" x 2 1/2"	6.000	152.40	578-00073	578-00278
6" x 3"	6.000	152.40	578-00074	578-00279
6" x 4"	6.000	152.40	578-00075	578-00280

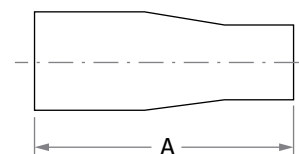

End Caps

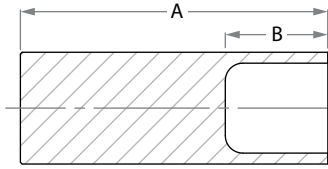

ECAP - End Cap

O.D. Size Inch	Dimensions				Catalog# EP	Catalog# BA
	A inch	A mm	B inch	B mm		
1/4"	1.70	34.75	0.456	11.582	576-00001	576-00012
3/8"	1.75	44.45	0.583	14.817	576-00002	576-00013
1/2"	1.75	44.45	0.583	14.817	576-00003	576-00014
3/4"	1.75	44.45	0.583	14.817	576-00004	576-00015
1"	1.75	44.45	0.583	14.817	576-00005	576-00016
1 1/2"	2.00	50.8	0.667	16.933	576-00006	576-00017
2"	2.00	50.8	0.667	16.933	576-00007	576-00018
2 1/2"	2.00	50.8	0.667	16.933	576-00008	576-00019
3"	2.00	50.8	0.667	16.933	576-00009	576-00020
4"	2.50	63.5	0.833	21.167	576-00010	576-00021
6"	4.77	121.0	2.625	66.667	576-00011	576-00022

* *How to order* - see page 6

** *For wall thickness please refer to page 9*

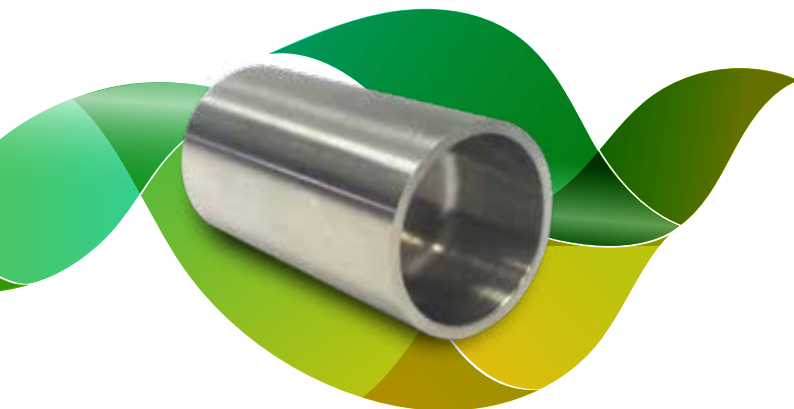

Coax - Tubes

Tubes

O.D. Size Inch			Dimensions				Catalog # BA/EP	
Inner Tube	X	Outer Tube	Wall Thickness Inner Tube		Wall Thickness Outer Tube		SciMax 20/10	
			t1 inch	t1 mm	t2 inch	t2 mm		
¼"	x	½"	0.035	0.89	0.049	1.24	581-00081	
⅜"	x	⅝"	0.035	0.89	0.049	1.24	581-00131	
½"	x	¾"	0.049	1.24	0.065	1.65	581-00088	
¾"	x	1"	0.065	1.65	0.065	1.65	581-00129	
1"	x	1¼"	0.065	1.65	0.065	1.65	581-00250	

* **How to order** - see page 7

*** Available upon request

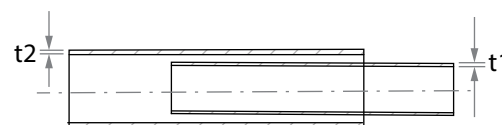

Coax - Elbows

EL90 - Elbow 90°

O.D. Size Inch			Dimensions						Catalog # BA/EP	
Inner Tube	X	Outer Tube	A	A mm	A1	A1	R	R	SciMax 20/10	
			inch	mm	inch	mm	inch	mm		
¼"	x	½"	4.0	101.6	3.0	76.2	1.125	28.6	585-00001	
⅜"	x	⅝"	4.0	101.6	3.0	76.2	1.125	28.6	585-00002	
½"	x	¾"	4.0	101.6	3.0	76.2	1.125	28.6	585-00011	
***¾"	x	1"	3.2	81.4	2.2	56.1	1.125	28.6	585-00013	
***1"	x	1¼"	4.0	102.2	2.5	64.2	1.500	38.1	585-00014	

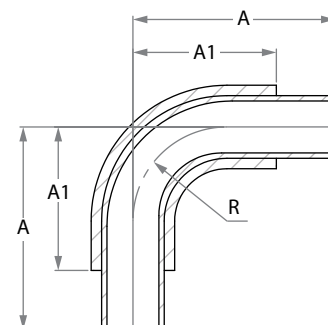

* **How to order** - see page 8

** For wall thickness please refer to page 15

*** External elbow welded from segments

EL45 - Elbow 45°

O.D. Size Inch			Dimensions						Catalog # BA/EP	
Inner Tube	X	Outer Tube	A	A	A1	A1	R	R	SciMax 20/10	
			inch	mm	inch	mm	inch	mm		
¼"	x	½"	3.25	82.6	2.25	57.2	1.125	28.6	585-00023	
⅜"	x	⅝"	3.25	82.6	2.25	57.2	1.125	28.6	585-00024	
½"	x	¾"	3.25	82.6	2.25	57.2	1.125	28.6	585-00025	
***¾"	x	1"	3.25	82.6	2.25	57.2	1.125	28.6	585-00021	
***1"	x	1¼"	3.75	95.3	2.25	57.2	1.500	38.1	585-00027	

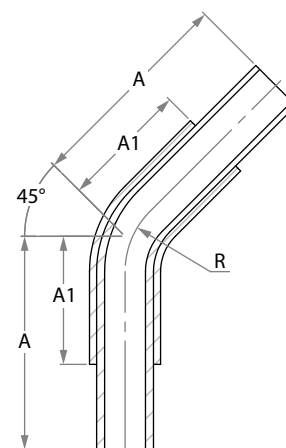

* **How to order** - see page 8

** For wall thickness please refer to page 15

*** External elbow welded from segments

Coax - Tees

ETEE - Equal Tee

O.D. Size Inch			Dimensions								Catalog # BA/EP	
Inner Tube	X	Outer Tube	A inch	A mm	A1 inch	A1 mm	B inch	B mm	B1 inch	B1 mm	SCiMax 20/10	
1/4"	x	1/2"	5.75	146.05	3.75	95.25	2.87	73.00	1.875	47.60	584-00001	
3/8"	x	5/8"	5.75	146.05	3.75	95.25	2.87	73.00	1.875	47.60	584-00002	
1/2"	x	3/4"	6.00	152.40	4.00	101.60	3.00	76.20	2.000	50.80	584-00009	
3/4"	x	1"	6.25	158.80	4.25	108.00	3.13	79.40	2.125	54.00	584-00008	
1"	x	1 1/4"	7.25	184.20	4.25	108.00	3.13	79.40	2.125	54.00	584-00010	

* **How to order** - see page 8

** **For wall thickness please refer to page 15**

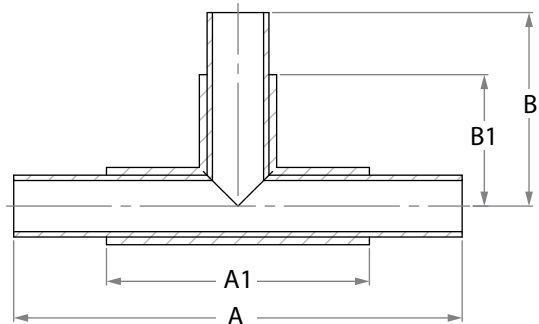

RTEE - Reducing Tee

O.D. Size Inch		Reducing O.D. Size Inch		Dimensions								Catalog # BA/EP		
Inner Tube	X	Outer Tube	Inner Tube	X	Outer Tube	A inch	A mm	A1 inch	A1 mm	B inch	B mm	B1 inch	B1 mm	SCiMax 20/10
3/8"	x	5/8"	1/4"	x	1/2"	5.75	146.1	3.75	95.3	2.875	73.0	1.875	47.6	584-00016
1/2"	x	3/4"	1/4"	x	1/2"	6.00	152.4	4.00	101.6	3.000	76.2	2.000	50.8	584-00017
1/2"	x	3/4"	3/8"	x	5/8"	6.00	152.4	4.00	101.6	3.000	76.2	2.000	50.8	584-00018
3/4"	x	1"	1/4"	x	1/2"	6.25	158.8	4.25	108.0	3.125	79.4	2.125	54.0	584-00019
3/4"	x	1"	3/8"	x	5/8"	6.25	158.8	4.25	108.0	3.125	79.4	2.125	54.0	584-00020
3/4"	x	1"	1/2"	x	3/4"	6.25	158.8	4.25	108.8	3.125	79.4	2.125	54.0	584-00005
1"	x	1 1/4"	1/4"	x	1/2"	7.25	184.2	4.25	108.0	3.125	79.4	2.125	54.0	***
1"	x	1 1/4"	3/8"	x	5/8"	7.25	184.2	4.25	108.0	3.125	79.4	2.125	54.0	***
1"	x	1 1/4"	1/2"	x	3/4"	7.25	184.2	4.25	108.0	3.125	79.4	2.125	54.0	584-00007
1"	x	1 1/4"	3/4"	x	1"	7.25	184.2	4.25	108.0	3.125	79.4	2.125	54.0	***

* **How to order** - see page 8

** **For wall thickness please refer to page 15**

*** **Available upon request**

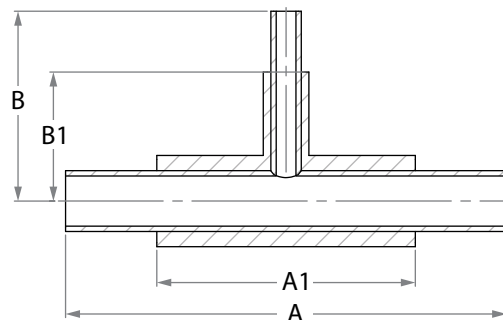

Coax Accesories

PTEE - Purge Tee

O.D. Size Inch		Dimensions							Catalog # BA/EP	
Inner Tube	X Outer Tube	D1 inch	D1 mm	A inch	A mm	B inch	B mm	FS	SciMax 20	
¼"	x ½"	0.25	6.35	3.75	95.25	1.875	47.65	0.25	584-00023	
⅜"	x ⅝"	0.62	15.75	3.75	95.25	1.950	49.53	0.25	584-00024	
½"	x ¾"	0.75	19.05	4.00	101.60	2.000	50.80	0.25	584-00012	
¾"	x 1"	1.00	25.4	4.25	108.00	2.125	54.00	0.25	584-00029	
1"	x 1¼"	1.25	31.75	4.25	108.00	2.260	57.40	0.25	584-00030	

* **How to order** - see page 8

** For wall thickness please refer to page 15

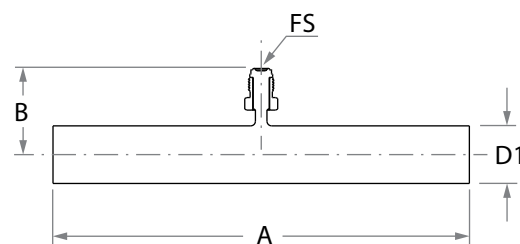

SLVE - Sleeve

O.D. Size Inch		Dimensions						Catalog # BA/EP
Outer Tube	D1 inch	D1 mm	D2 inch	D2 mm	A inch	A mm	SciMax 20	
½"	0.63	15.87	0.53	12.90	2.50	63.50	590-00007	
⅝"	0.75	19.00	0.63	16.10	2.50	63.50	590-00006	
¾"	0.87	22.00	0.76	19.25	2.50	63.50	590-00008	
1"	1.14	29.00	1.02	25.60	3.50	88.90	590-00004	
1¼"	1.38	35.00	1.26	32.00	3.50	88.90	590-00009	

* **How to order** - see page 8

** For wall thickness please refer to page 15



TERM - Terminator

O.D. Size Inch		Dimensions							Catalog # BA/EP	
Inner Tube	X Outer Tube	D1 inch	D1 mm	D2 inch	D2 mm	A inch	A mm	SciMax 20		
¼"	x ½"	0.50	12.7	0.26	6.60	1.25	31.75	590-00001		
⅜"	x ⅝"	0.63	15.9	0.38	9.70	1.25	31.75	590-00005		
½"	x ¾"	0.75	19.1	0.51	12.90	1.25	31.75	590-00010		
¾"	x 1"	1.00	25.4	0.76	19.30	2.00	50.80	590-00002		
1"	x 1¼"	1.25	31.8	1.00	25.40	2.13	54.00	590-00011		

* **How to order** - see page 8

** For wall thickness please refer to page 15

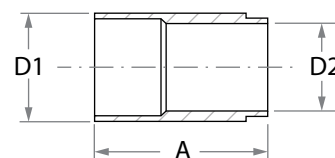

Laterals and Manifolds

EGMO offers top quality PCW, CFOS & UHP pre-fabricated laterals & manifolds for the semiconductor industry. Using EGMO's unique 3D internal welding technology, dead leg in laterals and manifold POC's are reduced to minimum:

- Reduce purge time
- Reduce number of welding on-site
- Reduce cost per line

With our new state of the art pre-fabrication plant and clean room facility, EGMO offers the best quality laterals & manifolds available on the market today.

Advantages

- Reducing field installation time
- All MP & EP manifolds are passivated
- Custom designed, manufactured, and 100% tested from a single source
- Reduced assembly & installation costs
- Warranted as a single part number
- Advanced and unique internal welding technology
- Reduced dead leg in branch
- Minimum weld per manifold

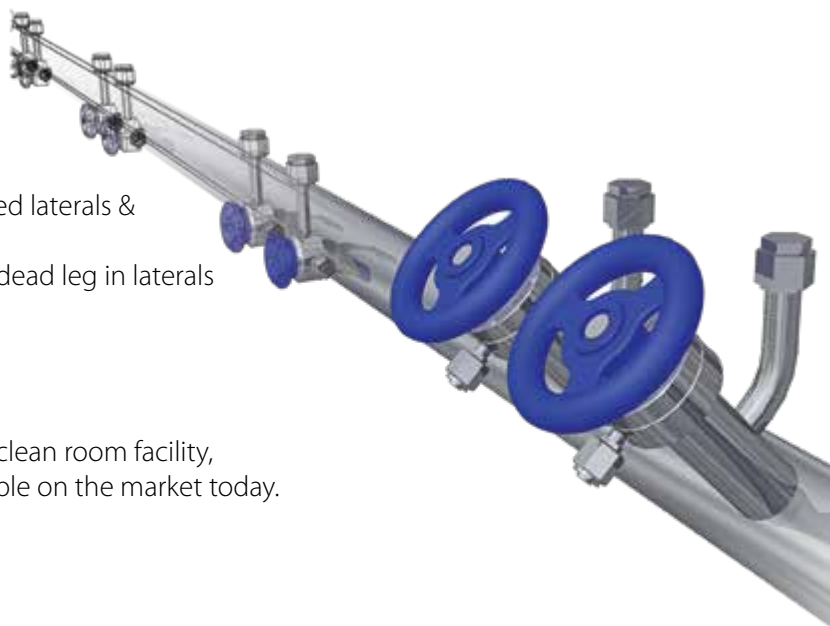

EGMO Laterals Application

- PCW & WFI water loops
- Bulk gases distribution systems
- Specialty gases distribution systems
- Mini Lateral for hook up

PCW Laterals

304L SCH10
 Diameters: 3" - 8"
 Material: 304L
 Standard: ASTM A312

CFOS Laterals

316L
 Diameters: 1" - 6"
 Material: 316L
 Standard: ASTM A269/ 270

UHP - Ultra High Pure Laterals

316L EP
 Diameters: 1" - 6"
 For UHP gases

Lateral Outlets

Weld connection
 Gland connection
 Clamp ferrule
 Ball valve
 Diaphragm valve
 Compression fittings

Applications

Ultra high purity gases
 Utility gas line laterals
 Process Cooling Water
 Short manifolds for gas cabinets



EGMO Manifold New Concept

Manifold Specifications

Sizes - 1/4" - 1"

Branches - 1/4" - 3/4"

Outlets - VCR Glands + Butt Weld

Standard Manifold

Based on a combination of a UHP tube welded to a mini butt-weld Tee fitting and a gland fitting, creating 3 weldings per each connection.

EGMO Advanced UHP Manifold

Based on a direct internal welding of the UHP Gland to the tube saves the use of the mini butt-weld tee and two weldings per each connection.

Main Advantages:

- Improve safety
- Improve quality
- Reduce cost

Implementation of Internal Welding Technology

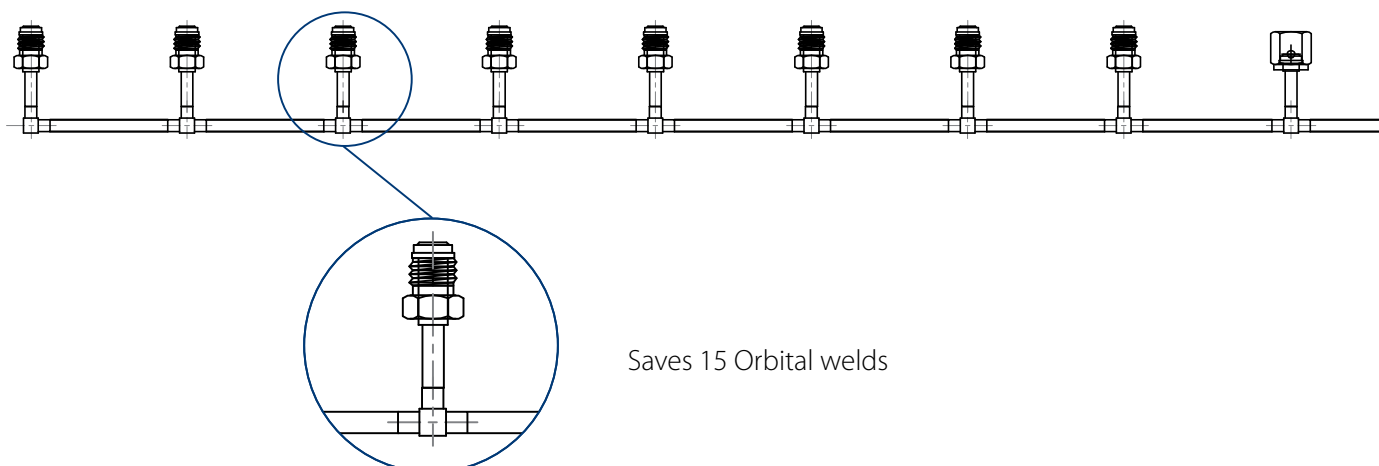
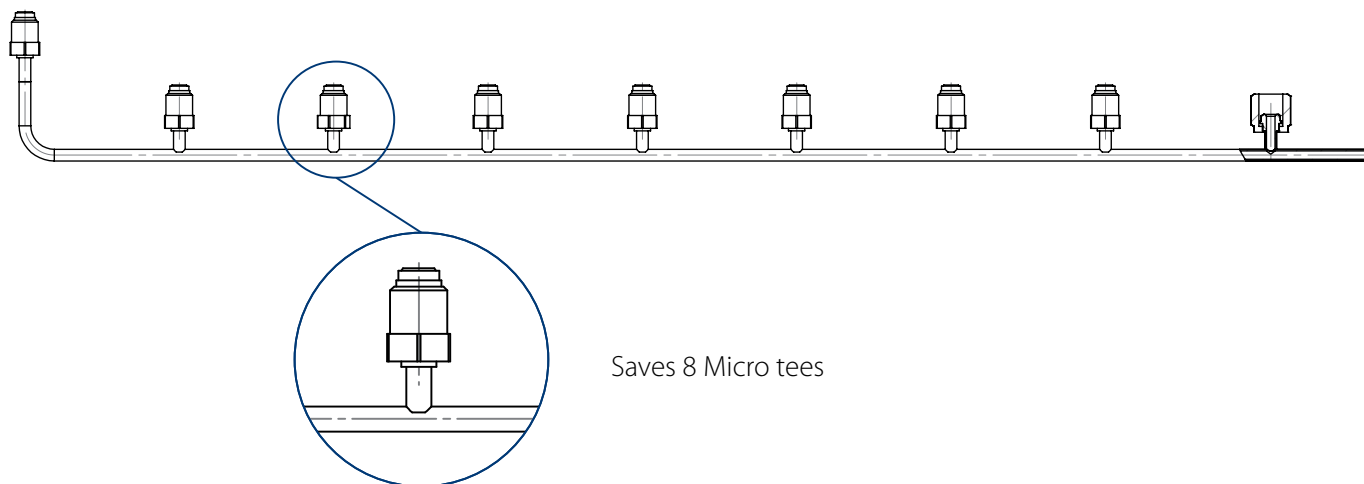

Technical Information

Tube Tolerances

Tubing specifications, ASTM A269/ A270/ A632

Tubing Diameter	Wall Thickness	OD Dimensional Specifications	Length	Wall Thickness Tolerance
		ASTM Spec.	ASTM Spec.	ASTM Spec.
¼"	.035"	+0.004"/-.000"	-0+1/8"	+/-10%
⅜"	.035"	+0.004"/-.000"	-0+1/8"	+/-10%
½"	.049"	+0.005"/-.005"	-0+1/8"	+/-10%
¾"	.065"	+0.005"/-.005"	-0+1/8"	+/-10%
1"	.065"	+0.005"/-.005"	-0+1/8"	+/-10%
1½"	.065"	+0.010"/-.010"	-0+1/8"	+/-10%
2"	.065"	+0.010"/-.010"	-0+1/8"	+/-10%
2½"	.065"	+0.010"/-.010"	-0+1/8"	+/-10%
3"	.065"	+0.010"/-.010"	-0+1/8"	+/-10%
4"	.083"	+0.015"/-.015"	-0+1/8"	+/-10%
6"	.109"	+0.030"/-.030"	-0+1/8"	+/-10%

Material and Properties

Chemical Composition for Various Stainless Steels

Material	Carbon	Manganese	Silicone	Chromium	Nickel	Molybdenum	Phosphorus	Sulfur
304	≤0.08	≤2.00	≤1.00	18.0-20.0	8.0-10.5	-	≤0.045	≤0.03
304L	≤0.03	≤2.00	≤1.00	18.0-20.0	8.0-12.0	-	≤0.045	≤0.03
316	≤0.08	≤2.00	≤1.00	16.0-18.0	10.0-14.0	2.0-3.0	≤0.045	≤0.03
316L	≤0.03	≤2.00	≤1.00	16.0-18.0	10.0-14.0	2.0-3.0	≤0.045	≤0.03

Operating Pressures of Stainless Steel Tubing

Size OD Tube	Nom. Wall	AISI 316L (1.4404)			AISI 304L (1.4306)		
		Working Pressure (psi/bar)	Yield Pressure (psi/bar)	Burst Pressure (psi/bar)	Working Pressure (psi/bar)	Yield Pressure (psi/bar)	Burst Pressure (psi/bar)
¼"	.035	5941/410	8436/582	20400/1407	6250/430	9200/665	21200/1500
⅜"	.035	3835/265	5445/375	13200/910	4150/285	6750/465	14500/1000
½"	.049	4550/314	6500/448	18200/1255	4880/336	7800/538	19500/1344
¾"	.065	3030/209	4300/296	12100/834	3250/224	5200/358	13000/896
1"	.065	2280/157	3300/227	9100/627	2440/168	3900/269	9800/896
1½"	.065	1520/105	2200/152	6100/421	1630/112	2600/179	6500/448
2"	.065	1140/79	1600/110	4600/317	1220/84	2000/138	4900/338
2½"	.065	910/63	1300/90	3600/248	980/68	1600/110	3900/269
3"	.065	760/52	1100/76	3000/207	810/56	1300/90	3300/228
4"	.083	730/50	1000/69	2900/200	780/54	1200/83	3100/214
6"	.109	640/44	900/62	2500/172	680/47	1100/76	2700/186

Fitting Tolerances

Tubing specifications, ASTM A269/ A270/ A632

Nominal OD Size	¼"	⅜"	½"	¾"	1"	1½"	2"	2½"	3"	4"	6"
O.D. Tolerance	±.005	±.005	±.005	±.005	±.005	±.008	±.008	±.010	±.010	±.015	±.030
Nominal Wall Thickness	.035	.035	.049	.065	.065	.065	.065	.065	.065	.083	.109
Wall Thickness Tolerance before EP	+0.03/- .004	+0.03/- .004	+0.05/- .008	+0.05/- .008	+0.05/- .008	+0.05/- .008	+0.05/- .008	+0.05/- .008	+0.05/- .008	+0.08/- .010	+0.15/- .015
Wall Thickness Tolerance after EP	+0.05/- .010	+0.05/- .010	+0.05/- .010	+0.05/- .010	+0.05/- .010	+0.05/- .010	+0.05/- .010	+0.05/- .010	+0.05/- .010	+0.08/- .012	+0.15/- .017
Control Length (C)	.750	.750	.750	.750	.750	.750	.750	.750	.750	.750	.750
Tangent Length (T)	1.500	1.500	1.500	1.500	1.500	1.500	1.500	1.500	1.750	2.000	2.500
Squareness Face to Tangent (B)	.005	.005	.005	.005	.008	.008	.008	.010	.016	.016	.030
Off Angle (O)	.009	.012	.014	.018	.025	.034	.043	.054	.068	.086	.135
Off Plane (P)	±.030	±.030	±.030	±.030	±.030	±.050	±.050	±.050	±.050	±.060	±.060

* All dimensions are in Inches

• Roundness

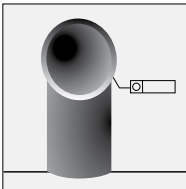

• Wall Thickness

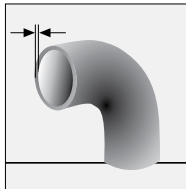

• Squareness Face to Tangent

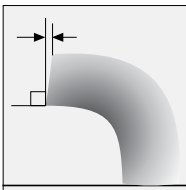

• Off Angle

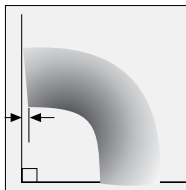

• Off Plane

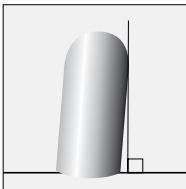

• Height

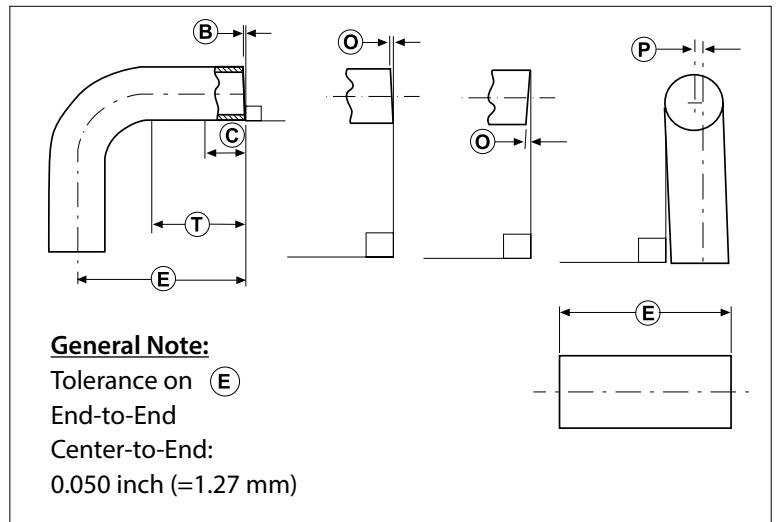
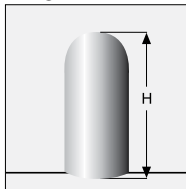

MTR - Material Test Report

The MTR is the reference document for the entire history of the production processes and the raw materials used to make the SCiMax component.

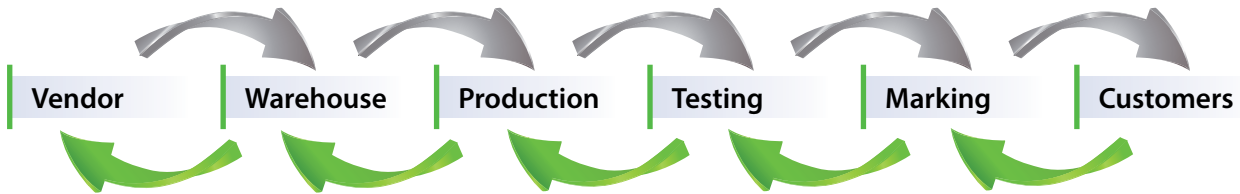

The MTR document is easily generated on-line via www.egmo.co.il using only the job number as input. The job number is the product identification number which represents all processes and raw materials related to the specific item.

ON-LINE MTR

Please, enter job/certificate number:



The MTR is also available for download with QR CODE

The MTR format provides the following information:

- Part number, part description and job number
- Material type
- Heat Number per each component describing the fitting and its associated properties:
 - Tube dimensions and standards
 - Chemical composition
 - Mechanical properties
 - Visual, dimensional, corrosion, EDDY current testing, flaring and flattening, PMI Test
- Certificate of Compliance (please refer to table page 5)

Customized Components

EGMO, VNE, and NEUMO are distinguished by their unique ability to provide the highest quality stainless steel products - ranging from special fittings, connectors, electro polished vessels and tanks with the most advanced technology, and other special accessories - for a cross-industry clientele.

Our abilities have developed and progressed over the years, allowing us to offer a one-of-a-kind business opportunity: custom stainless steel products and systems, manufactured according to client specifications and needs.

Our Vessels & Custom Products can be designed to meet any requirement, including vessels, abnormal sizes, special angles, sprinklers, subsystems and many more - all in compliance with industrial regulations.



NEUMO EHRENBERG GROUP

GLOBAL LOCATIONS



NEUMO GmbH+Co. KG (D)

Tel: +49 (0) 7043 36 0
Fax: +49 (0) 7043 36 179
E-Mail: info@neumo.de
www.neumo.de
GERMANY



VNE Corporation

Tel: +1 800 356 1111
+1 608 756 4930
Fax: +1 608 756 3643
E-Mail: stainless@vncorp.com
www.vnestainless.com
U.S.A



EGMO Ltd.

Tel: +972 (0) 4 9855 176
+972 (0) 4 9855 111
Fax: +972 (0) 4 9855 175
E-Mail: salese@egmo.co.il
www.egmo.co.il
ISRAEL



NEUMO-EGMO Spain S.L

Tel: +34 977 524 914
Fax: +34 977 524 898
E-Mail: neumo-es@neumo-es.com
www.neumo-es.com
SPAIN



HPT Inc.

Tel: +845.452.1103
+800.284.4478
E-Mail: sales@hptinc.com
<http://www.hptinc.com/>
U.S.A



Herrli AG

Tel: +41 (0) 31 750 12 11
Fax: +41 (0) 31 750 12 00
E-Mail: info@herrli.net
www.herrli.net
SWITZERLAND



NEUMO Polska Sp. z.o.o

Tel: +48 (0) 46 833 4306
Fax: +48 (0) 46 832 5626
E-Mail: neumo@neumo.pl
POLAND



NEUMO Turkey

Tel: +90 (212) 875 01 41
Fax: +90 (212) 875 23 13
E-Mail: info@neumo.com.tr
www.neumo.com.tr
TURKEY



NEUMO Budapest Kft

Tel: +36 (1) 3174177
+36 (1) 3185982
Fax: +36 (1) 266 8765
E-Mail: neumo@neumo.hu
www.neumo.hu
HUNGARY



NEUMO GmbH + Co. KG

Tel: +84 (4) 3773 6586
Fax: +84 (4) 3773 6587
E-Mail: info@neumo.com.vn
www.neumo.co.vn
VIETNAM



NEUMO - VARGUS (Shanghai)

Trading Co., Ltd
Tel: +86 (21) 51688300
Fax: +86 (21) 51688380
E - Mail: info@neumo.com.cn
CHINA



NEUMO UK Ltd.

Tel: +44 (0) 1952 583 999
Fax: +44 (0) 1952 583 958
E-Mail: stainless@neumo.co.uk
www.neumo.co.uk
UNITED KINGDOM



AWH Armaturenwerke (D)

Hötensleben GmbH
Tel: +49 (0) 39405 92 0
Fax: +49 (0) 39405 92 111
E-Mail: info@awh.de
www.awh.de



NEUMO

Tel: +353 (0)21 4975540
Cel: +353 (0)87 2330469
E-Mail: dosullivan@neumo.de
www.neumo.de/en/
IRELAND



Damstahl a/s (Denmark)

Tel: +45 (0) 8794 4000
Fax: +45 (0) 8794 4150
E-Mail: ds@damstahl.com
www.damstahl.dk
DENMARK



Damstahl GmbH (D)

Tel: +49 (0) 2173 797 0
Fax: +49 (0) 2173 797 274
E-Mail: ds@damstahl.de
www.damstahl.de



Damstahl a/s Oslo (N)

Tel: +47 5615 1570
Fax: +47 5615 1571
E-Mail: dano@damstahl.com
www.damstahl.no
NORWAY



Damstahl a/b (Sweden)

Tel: +46 87 61 71 00
Fax: +46 87 61 14 05
www.damstahl.se
SWEDEN

